

CMOS Analog Switches

Features

- $\pm 15\text{-V}$ Input Range
- Fast Switching— t_{ON} : 110 ns
- Low $r_{DS(on)}$: 30 Ω
- Single Supply Operation
- CMOS Logic Levels
- Micropower: 30 nW

Benefits

- Full Rail-to-Rail Analog Signal Range
- Low Signal Error
- Wide Dynamic Range
- Low Power Dissipation

Applications

- Low Level Switching Circuits
- Programmable Gain Amplifiers
- Portable and Battery Powered Systems

Description

The DG304A through DG307A series of monolithic CMOS switches were designed for applications in communications, instrumentation and process control. This series is well suited for applications requiring fast switching and nearly flat on-resistance over the entire analog range.

Designed on the Siliconix PLUS-40 CMOS process to achieve low power consumption and excellent on/off switch performance, these switches are ideal for

battery powered applications, without sacrificing switching speed. Break-before-make switching action is guaranteed, and an epitaxial layer prevents latchup. Single supply operation (for positive switch voltages) is allowed by connecting the $V-$ rail to 0 V.

Each switch conducts equally well in both directions when on, and blocks up to the supply voltage when off. These switches are CMOS input compatible.

Functional Block Diagram and Pin Configuration

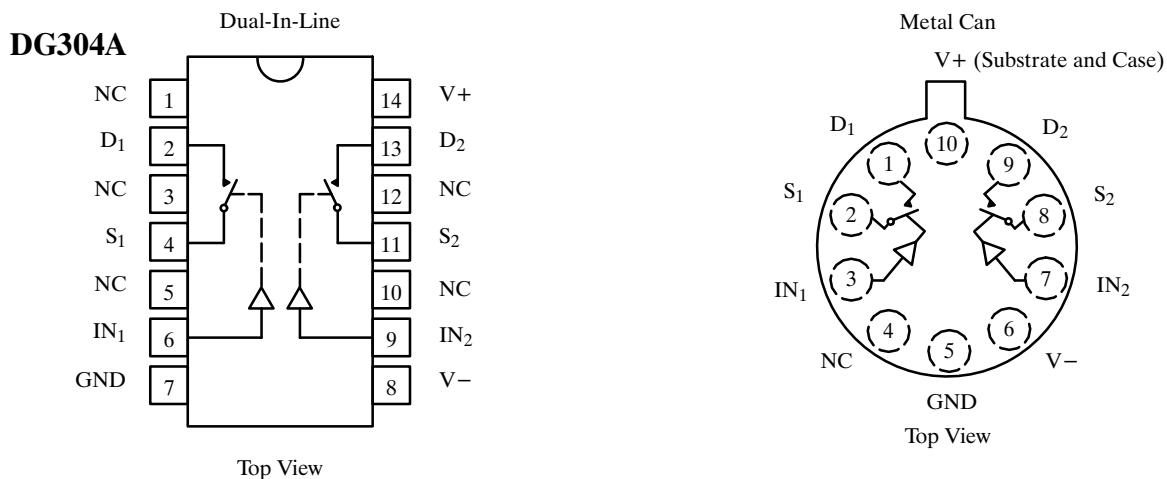

Ordering Information – DG304A

Temp Range	Package	Part Number
-0 to 70°C	14-Pin Plastic DIP	DG304ACJ
-55 to 125°C	14-Pin CerDIP	DG304AAK/883
		JM38510/11605BCA
	10-Pin Can	JM38510/11605BIA
	14-Pin Sidebrazed	JM38510/11605BCC

Truth Table

Logic	Switch
0	OFF
1	ON

Logic "0" $\leq 3.5\text{ V}$
 Logic "1" $\geq 11\text{ V}$
 Switches Shown for Logic "0" Input

DG304A/305A/306A/307A

Functional Block Diagram and Pin Configuration (Cont'd)

DG305A

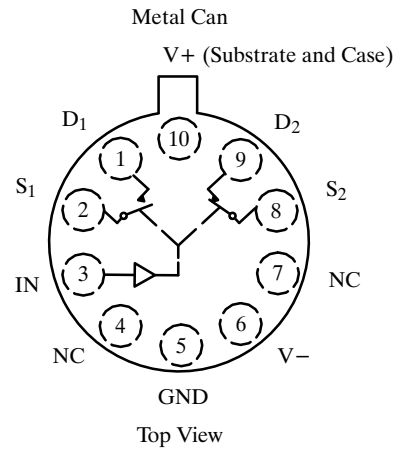
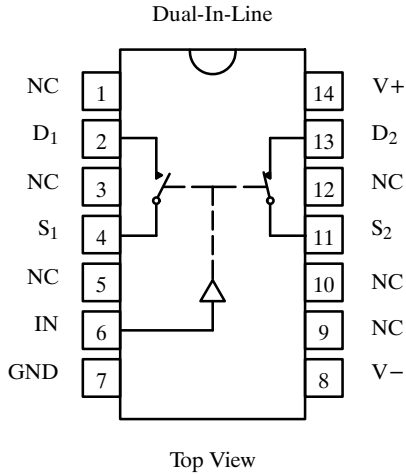

Ordering Information – DG305A

Temp Range	Package	Part Number
-55 to 125°C	14-Pin CerDIP	JM38510/11605BCA
	10-Pin Can	JM38510/11606BIC
	14-Pin Sidebrazed	JM38510/11606BCA

Truth Table

Logic	SW ₁	SW ₂
0	OFF	ON
1	ON	OFF

Logic "0" ≤ 3.5 V
 Logic "1" ≥ 11 V

Switches Shown for Logic "0" Input

DG306A

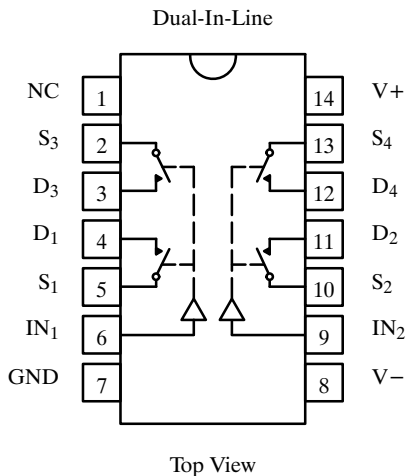

Truth Table

Logic	Switch
0	OFF
1	ON

Logic "0" ≤ 3.5 V
 Logic "1" ≥ 11 V

Switches Shown for Logic "0" Input

Ordering Information – 306A

Temp Range	Package	Part Number
-0 to 70°C	14-Pin Plastic DIP	DG306ACJ
-55 to 125°C	14-Pin CerDIP	DG306AAK/883
		JM38510/11607BCA
	14-Pin Sidebrazed	JM38510/11607BCC

Functional Block Diagram and Pin Configuration (Cont'd)

DG307A

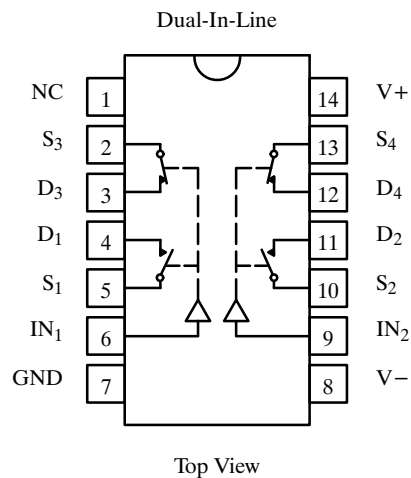

Four SPST Switches per Package

Truth Table

Logic	SW ₁ , SW ₂	SW ₃ , SW ₄
0	OFF	ON
1	ON	OFF

Logic "0" ≤ 3.5 V
 Logic "1" ≥ 11 V

Switches Shown for Logic "0" Input

Ordering Information – 307A

Temp Range	Package	Part Number
0 to 70°C	14-Pin Plastic DIP	DG307ACJ
-25 to 85°C	14-Pin CerDIP	DG307ABK
		DG307AAK
		DG307AAK/883
		JM38510/11608BCA
-55 to 125°C	14-Pin Sidebrazed	JM38510/11608BCC

Absolute Maximum Ratings

Voltages Referenced to V-

V+ 44 V

GND 25 V

Digital Inputs^a, V_S, V_D (V-) -2 V to (V+) +2V or
 30 mA, whichever occurs first

Current, Any Terminal 30 mA

Continuous Current, S or D
 (Pulsed at 1 ms, 10% duty cycle max) 100 mA

Storage Temperature (AAA, AAK, ABK Suffix) -65 to 150°C
 (ACJ Suffix) -65 to 125°C

Power Dissipation^b

14-Pin Plastic DIP^c 470 mW

14-Pin CerDIP^d 825 mW

10-Pin Metal Can^e 450 mW

Notes:

- Signals on S_X, D_X, or IN_X exceeding V+ or V- will be clamped by internal diodes. Limit forward diode current to maximum current ratings.
- All leads welded or soldered to PC Board.
- Derate 11 mW/°C above 75°C
- Derate 6.5 mW/°C above 25°C
- Derate 6 mW/°C above 75°C

DG304A/305A/306A/307A

Specifications^a

Parameter	Symbol	Conditions Unless Otherwise Specified $V_+ = 15\text{ V}, V_- = -15\text{ V}$ $V_{IN} = 3.5\text{ V or } 11\text{ V}^f$	Temp ^b	Typ ^c	A Suffix –55 to 125°C		B, C Suffix –25 to 85°C 0 to 70°C		Unit
					Min ^d	Max ^d	Min ^d	Max ^d	
Analog Switch									
Analog Signal Range ^e	V_{ANALOG}		Full		–15	15	–15	15	V
Drain-Source On-Resistance	$r_{DS(on)}$	$V_D = \pm 10\text{ V}, I_S = 10\text{ mA}$	Room Full	30		50 75		50 75	Ω
Source Off Leakage Current	$I_{S(off)}$	$V_S = \pm 14\text{ V}$ $V_D = \mp 14\text{ V}$	Room Full	± 0.1	–1 –100	1 100	–5 –100	5 100	nA
Drain Off Leakage Current	$I_{D(off)}$	$V_S = \pm 14\text{ V}$ $V_D = \mp 14\text{ V}$	Room Full	± 0.1	–1 –100	1 100	–5 –100	5 100	
Drain On Leakage Current	$I_{D(on)}$	$V_D = V_S = \pm 14\text{ V}$	Room Full	± 0.1	–2 –200	2 200	–5 –200	5 200	
Digital Control									
Input Current with Input Voltage High	I_{INH}	$V_{IN} = 5\text{ V}$	Room Full	–0.001	–1 –1		–1		μA
		$V_{IN} = 15\text{ V}$	Room Full	0.001		1 1		1	
Input Current with Input Voltage Low	I_{INL}	$V_{IN} = 0\text{ V}$	Room Full	–0.001	–1 –1		–1		
Dynamic Characteristics									
Turn-On Time	t_{ON}	See Figure 2	Room	110		250			ns
Turn-Off Time	t_{OFF}		Room	70		150			
Break-Before-Make Time	t_{OPEN}	DG305A/307A ONLY See Figure 3	Room	50					
Charge Injection	Q	$C_L = 1\text{ nF}, R_{gen} = 0$ $V_{gen} = 0\text{ V}, \text{ See Figure 4}$	Room	30					pC
Source-Off Capacitance	$C_{S(off)}$	$f = 1\text{ MHz}, V_S = 0\text{ V}$ $V_S, V_D = 0\text{ V}$	Room	14					pF
Drain-Off Capacitance	$C_{D(off)}$		Room	14					
Channel-On Capacitance	$C_{D(on)}$		Room	40					
Input Capacitance	C_{IN}		$f = 1\text{ MHz}$	$V_{IN} = 0\text{ V}$	Room	6			
			$V_{IN} = 15\text{ V}$	Room	7				
Off-Isolation	OIRR	$V_{IN} = 0\text{ V}, R_L = 1\text{ k}\Omega$	Room	62					dB
Crosstalk (Channel-to-Channel)	X_{TALK}	$V_S = 1\text{ V}_{rms}, f = 500\text{ kHz}$	Room	74					
Power Supplies									
Positive Supply Current	I+	$V_{IN} = 15\text{ V or } 0\text{ V}$ (All Inputs)	Room Full	0.001		10 100		100	μA
Negative Supply Current	I–		Room Full	–0.001	–10 –100		–100		

Notes:

- Refer to PROCESS OPTION FLOWCHART (Section 5 of the 1994 Data Book or FaxBack number 7103).
- Room = 25°C, Full = as determined by the operating temperature suffix.
- Typical values are for DESIGN AID ONLY, not guaranteed nor subject to production testing.
- The algebraic convention whereby the most negative value is a minimum and the most positive a maximum, is used in this data sheet.
- Guaranteed by design, not subject to production test.
- V_{IN} = input voltage to perform proper function.

Typical Characteristics

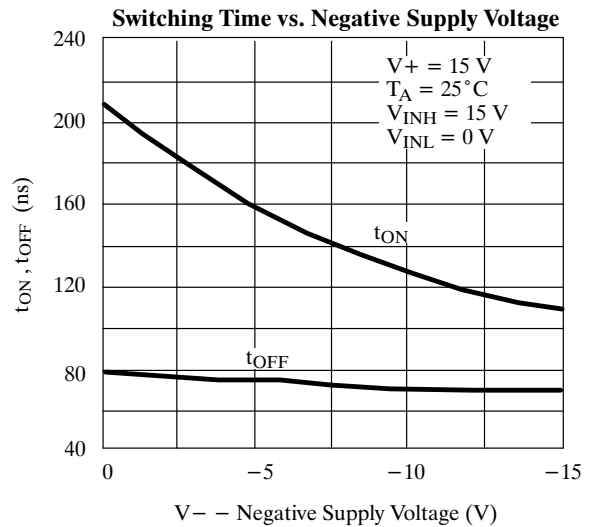
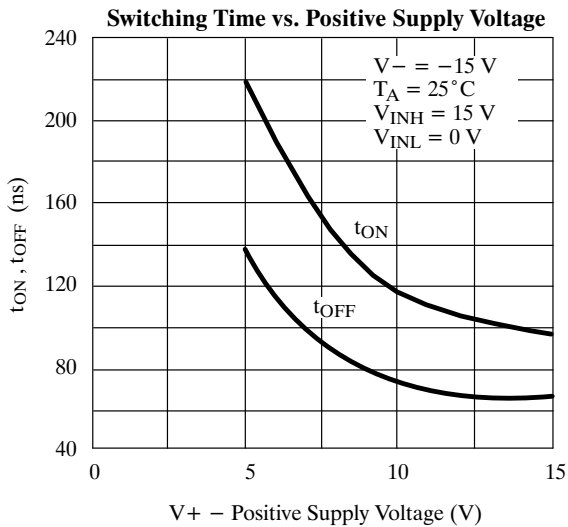
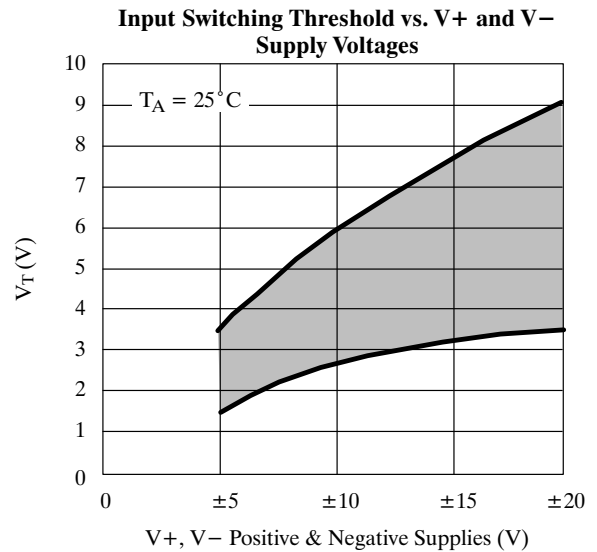
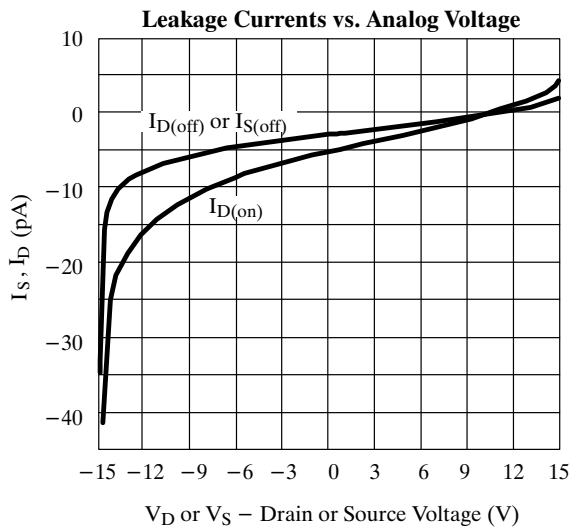
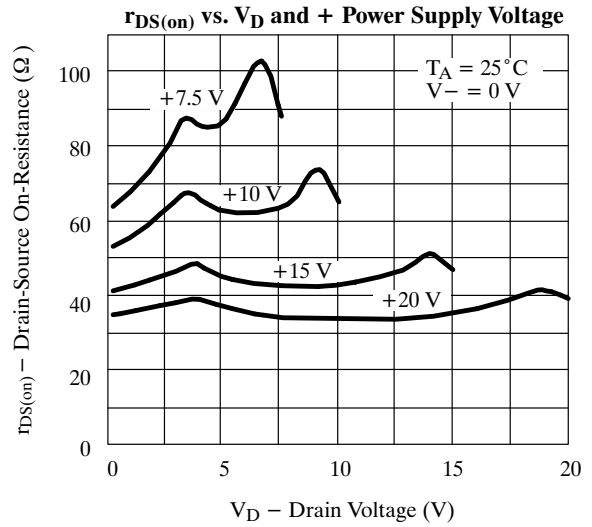
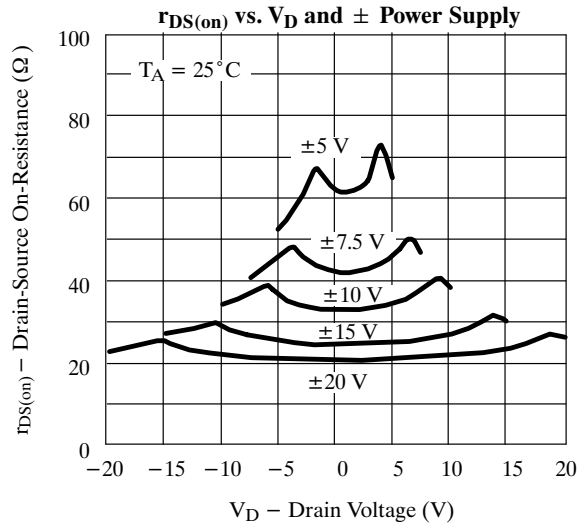

DG304A/305A/306A/307A

Typical Characteristics (Cont'd)

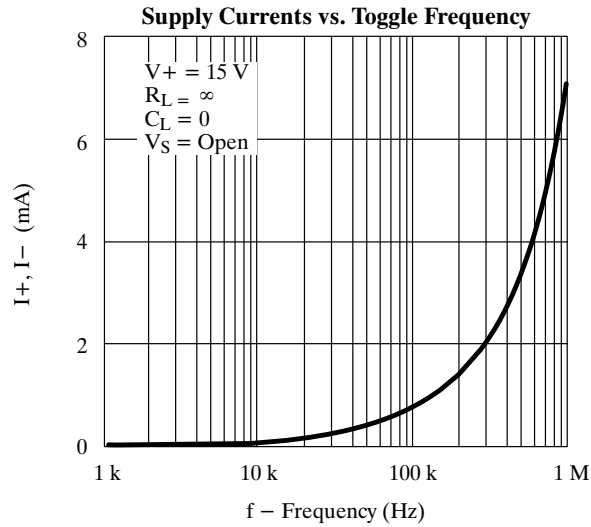

Schematic Diagram (Typical Channel)

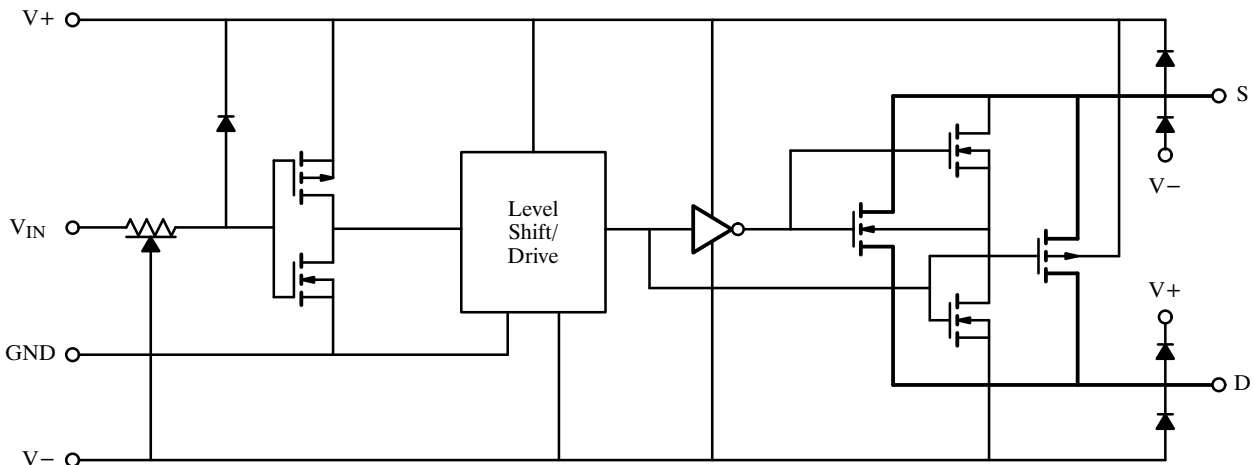

Figure 1.

Test Circuits

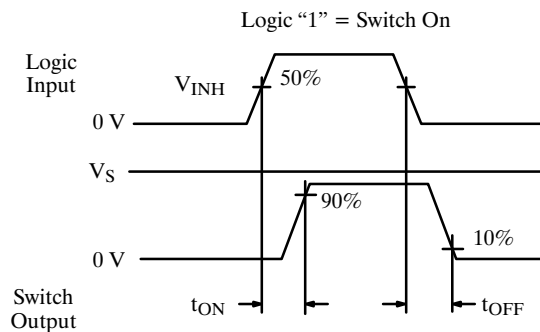
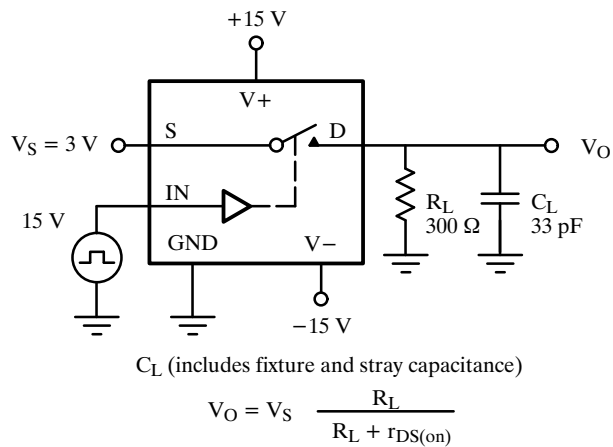

Figure 2. Switching Time

Test Circuits (Cont'd)

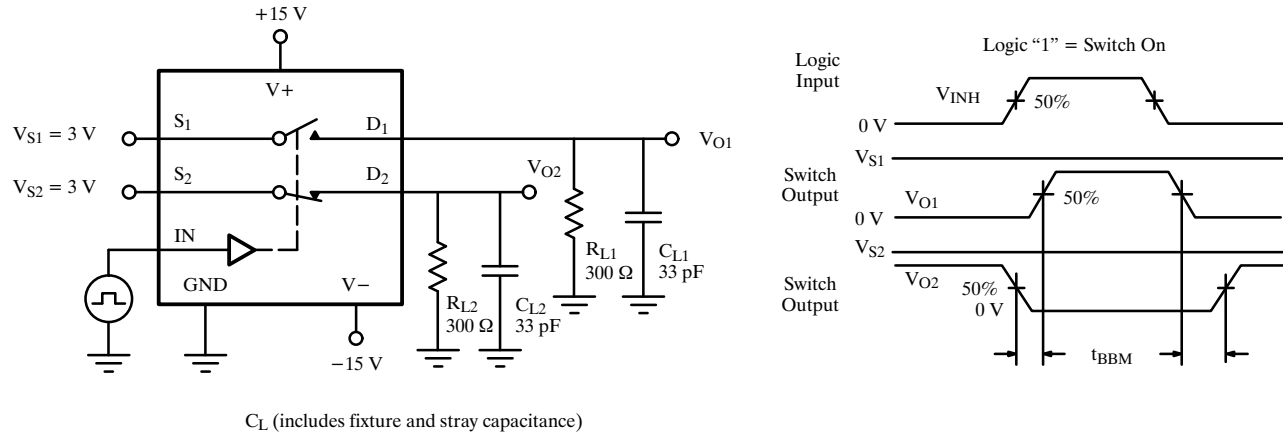

Figure 3. Break-Before-Make SPDT (DG305A, DG307A)

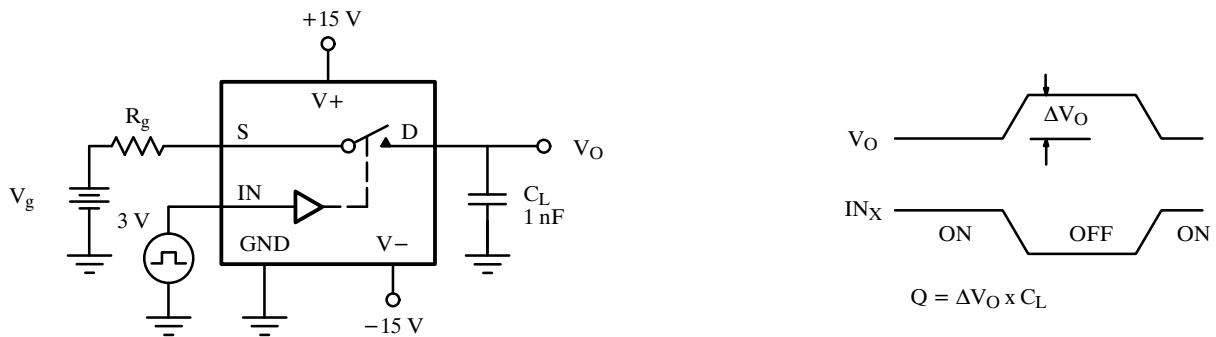

Figure 4. Charge Injection

Application Hints^a

V+ Positive Supply Voltage (V)	V- Negative Supply Voltage (V)	GND Voltage (V)	V _{IN} Logic Input Voltage V _{INH(min)} /V _{INL(max)} (V)	V _S or V _D Analog Voltage Range (V)
15	-15	0	11/3.5	-15 to 15
20	-20	0	11/3.5	-20 to 20
15	0	0	11/3.5	0 to 15

Notes:

a. Application Hints are for DESIGN AID ONLY, not guaranteed and not subject to production testing.

DG304A/305A/306A/307A

Applications

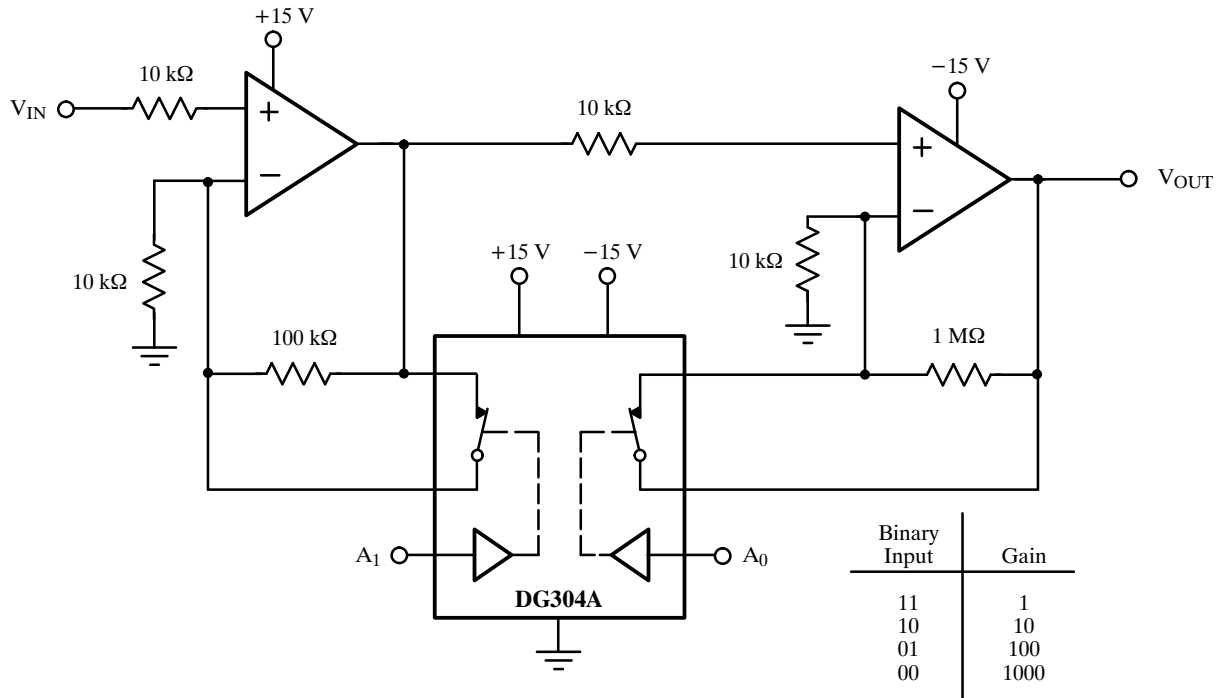

Figure 5. Low Power Binary to 10^n Gain Low Frequency Amplifier

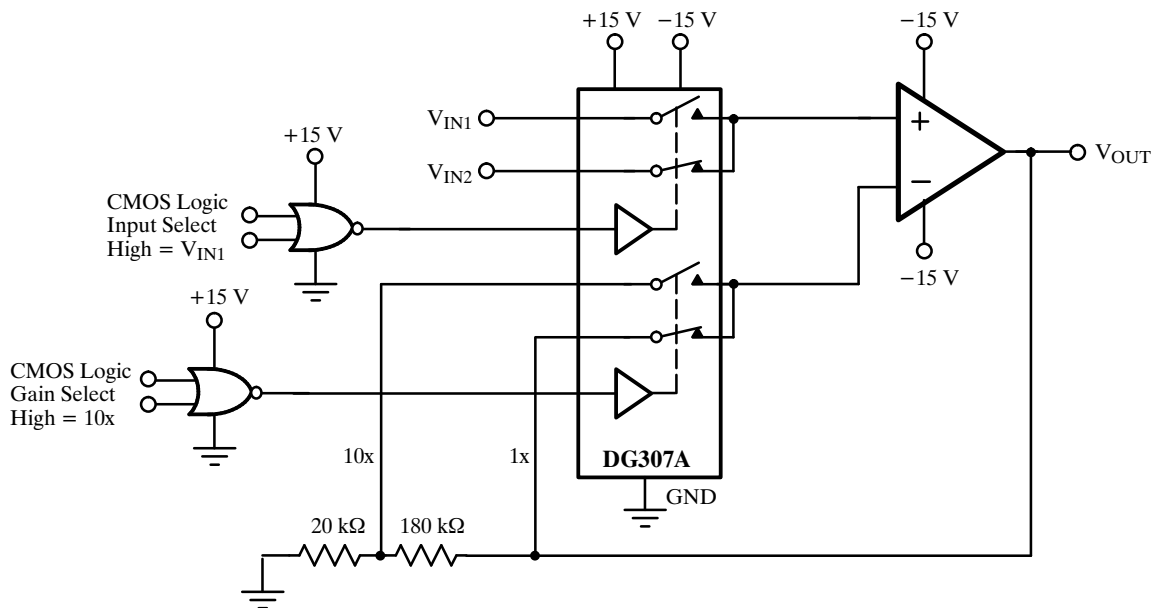

Figure 6. Low Power Non-Inverting Amplifier with Digitally Selectable Inputs and Gain